

DX Air-Cooled Series Nanosecond Lasers

www.photonix.com

Photonics Industries' DX Air-Cooled Series nanosecond DPSS lasers, with a small, air-cooled form factor (275 in³, ~15.5 lbs or ~7 kg), offer the highest powers air-cooled in the market, with up to 10 W UV and up to 20 W green. The extra small DX Air-Cooled Series (152.1 in³, ~10 lbs or ~4.5 kg), outputs average powers of 1 W UV and up to 2 W green. The DX Air-Cooled Series combines capabilities in power, air-cooling, and a small mechanical footprint for optimal integration in industrial laser microprocessing systems. As an exceptionally small DPSS laser, the DX Air-Cooled Series nanosecond laser is the ideal laser source solution from micron-precision marking, to solar cell processing, and to many more industrial laser microprocessing applications.



Applications

- Cutting, drilling, welding, scribing, marking, intra-marking, patterning, dielectric grooving, annealing, repair
- Laser Marking on-the-fly (MOTF), Laser Etching, Laser Patterning, Short Pulse Marking, High Precision Marking, DPSS Laser Marking Systems
- Flat Panel Display Repair
- Solar Cell Laser Structuring, P1 & P3 Solar Cell Processing
- Stereolithography (SLA), Rapid Prototyping 3D Printing, UV Laser 3D Printing
- Mass Spectrometry Systems, MALDI
- LIDAR, Autonomous Systems, 3-D Scanning Systems
- Thin Display Cutting & Drilling, Thin Film Transistor (TFT) Drilling

Features

- Highest powers air-cooled in the market
Up to 10 W, UV, Air-Cooled
Up to 20 W, Green, Air-Cooled
- Short pulse widths:
~15 ns at 50 kHz
~20 ns at 100 kHz
- Wider repetition rate range than leading competitors, fulfilling higher throughput criteria:
Single shot up to 300 kHz, UV
Single shot up to 500 kHz, Green
- Reliable, low COO, non-consumable design
Patented intracavity harmonic UV & Green generation, no damaging indexing of the harmonic crystals
- Small, air-cooled form factor
Water-cooling option available
- Excellent TEM00 beam quality:
Typical M² < 1.1
- Total Pulse Control:
Duty Control to change output power while allowing for longer pulse widths than the standard operating values
PEC (Power or Pulse Energy Control)
Burst Mode
- Power monitoring and calibration
Real-time power monitoring
Auto power calibration

	DX-355-1	DX-355-5	DX-355-8	DX-355-10
Beam and output specifications				
Wavelength	355 nm			
Average power	1 W at 50 kHz	5 W at 50 kHz	8 W at 50 kHz	10 W at 50 kHz
Pulse energy	20 μJ at 50 kHz	100 μJ at 50 kHz	160 μJ at 50 kHz	200 μJ at 50 kHz
Pulse width	< 15 ns at 50 kHz 20±4 ns at 100 kHz			
Pulse repetition rate ¹	Single shot to 200 kHz (option up to 300 kHz)			
Pulse-to-pulse stability ²	< 2% rms			
Long term power stability ³	< 2% rms			
Beam spatial mode	TEM ₀₀ M ² < 1.1			
Beam pointing stability	< 20 μrad			
Beam divergence	< 2.5 mrad			
Beam roundness	~90%			
Beam diameter, at exit	~0.3 mm			~0.4 mm
Polarization ratio	Horizontal; 100:1			
Operational specifications and system characteristics				
Interface	RS232, Ethernet, Software GUI, External TTL Triggering			
Warm-up time	< 5 minutes from standby, < 10 minutes from cold start			
Electrical requirement	100-240 V AC; or 15 V DC, 13.4 A			
Line frequency	50-60 Hz			
Ambient temperature ⁴	Ambient 10°C to 30°C (50°F to 86°F) Operating Range, Relative Humidity 90% Max., non-condensing			
Storage conditions	-10°C to 40°C; Sea Level to 12,000 m; 0% to 90% Relative Humidity, non-condensing			
Power consumption	~50 W	~130 W		
Dimensions (LxWxH)	9 x 5 x 3.38 in	11 x 5 x 5 in		
Weight	~10 lbs (~4.5 kg)	~15.5 lbs (~7 kg)		
Cooling system ⁵	Air-cooled			

[1.] Lower pulse repetition rates (down to < 30 kHz) performance achieved by pulse energy capping. [2.] Measured at ambient temperature ± 2°C. [3.] Measured over 8 hours ± 1°C. [4.] For operation of the laser outside of the specified temperature range, contact us. [5.] For water-cooled heatsink option, contact us.

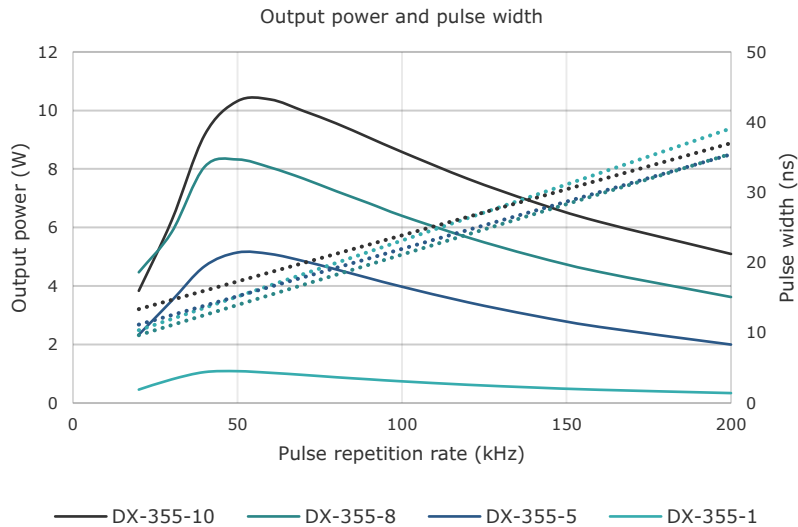

	DX-532-2	DX-532-10	DX-532-15	DX-532-20
Beam and output specifications				
Wavelength	532 nm			
Average power	2 W at 50 kHz	10 W at 50 kHz	15 W at 50 kHz	20 W at 70 kHz
Pulse energy	40 μJ at 50 kHz	200 μJ at 50 kHz	300 μJ at 50 kHz	> 285 μJ at 70 kHz
Pulse width	< 15 ns at 50 kHz < 25 ns at 100 kHz			
Pulse repetition rate ¹	Single shot to 300 kHz (option up to 500 kHz)			
Pulse-to-pulse stability ²	< 2% rms			
Long term power stability ³	< 2% rms			
Beam spatial mode	TEM ₀₀ M ² < 1.1			
Beam pointing stability	< 20 μrad			
Beam divergence	< 2.5 mrad			< 4 mrad
Beam roundness	~90%			
Beam diameter, at exit	~0.5 mm			
Polarization ratio	Vertical; 100:1			
Operational specifications and system characteristics				
Interface	RS232, Ethernet, Software GUI, External TTL Triggering			
Warm-up time	< 5 minutes from standby, < 10 minutes from cold start			
Electrical requirement	100-240 V AC; or 15 V DC, 13.4 A			
Line frequency	50-60 Hz			
Ambient temperature ⁴	Ambient 10°C to 30°C (50°F to 86°F) Operating Range, Relative Humidity 90% Max., non-condensing			
Storage conditions	-10°C to 40°C; Sea Level to 12,000 m; 0% to 90% Relative Humidity, non-condensing			
Power consumption	~50 W	~130 W		
Dimensions (LxWxH)	9 x 5 x 3.38 in	11 x 5 x 5 in		
Weight	~10 lbs (~4.5 kg)	~15.5 lbs (~7 kg)		
Cooling system ⁵	Air-cooled			

[1.] Lower pulse repetition rates (down to < 30 kHz) performance achieved by pulse energy capping. [2.] Measured at ambient temperature ± 2°C. [3.] Measured over 8 hours ± 1°C. [4.] For operation of the laser outside of the specified temperature range, contact us. [5.] For water-cooled heatsink option, contact us.

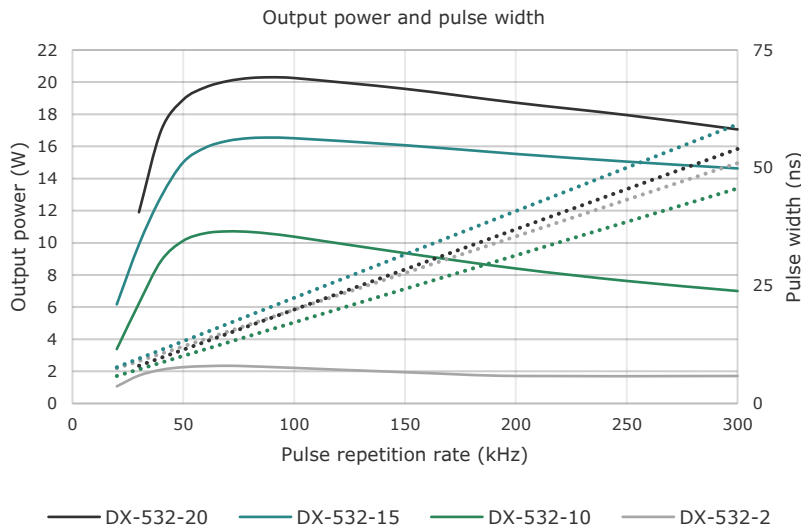

Dimensional Drawings

**DX-355-5, DX-355-8, DX-355-10
DX-532-10, DX-532-15, DX-532-20**

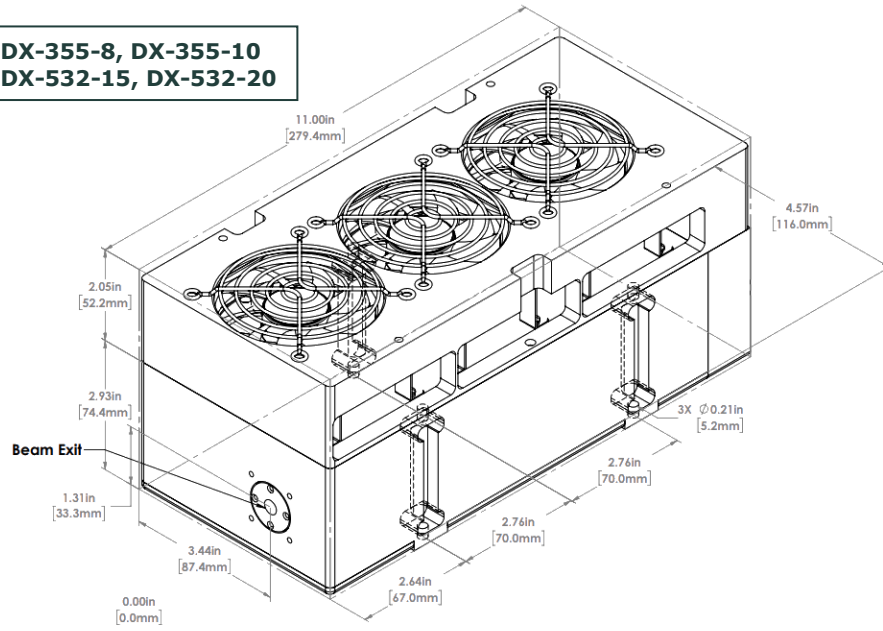

**DX-355-1
DX-532-2**

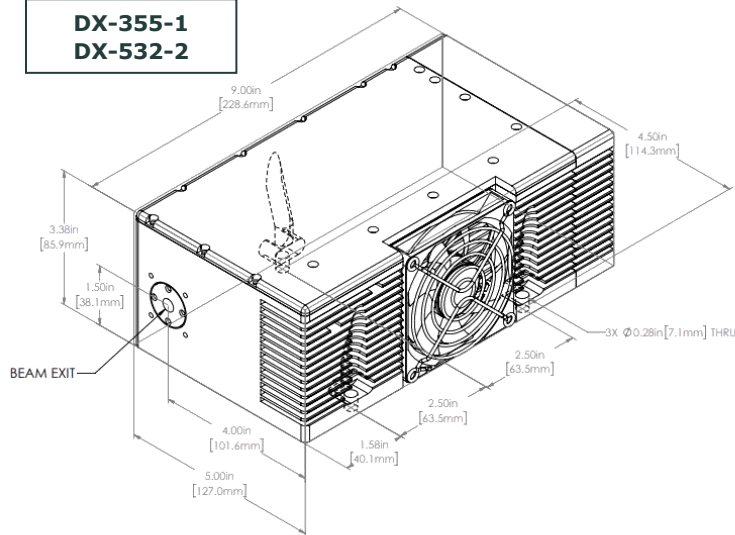

Product specifications, characteristics, and dimensional drawings are subject to change without notice.

Photonics Industries conforms to provisions of US 21 CFR 1040.10 & 1040.11 and is made under one or more US patents listed below:
9,531,147, 8,817,831, 7,869,471, 7,346,092, 7,082,149, 7,079,557, 6,999,483, 6,980,574, 6,961,355, 6,842,293, 6,762,405, 6,690,692, 6,587,487, 6,584,134, 6,366,596, 6,356,578, 6,327,281, 6,246,707, 6,229,829, 6,108,356, 6,061,370, 6,028,620, 5,936,983, 5,898,717 and Pending Patents

Copyright © 2023 by Photonics Industries International, Inc.

Main Headquarters: 1800 Ocean Ave, Ronkonkoma, New York 11779, United States

Photonics Industries International is the pioneer of intracavity harmonic lasers and is at the forefront of developing, manufacturing and marketing a wide range of nanosecond, sub-nanosecond, picosecond and femtosecond lasers for industrial, scientific, defense, and medical industries. Check out our products and see how we can help you apply our lasers to your needs.

[Website](#) - [Products](#) - [Applications](#) - [Company](#) - [Contact](#) - [International Network](#)

