

## DP Series High Pulse Energy TEM<sub>00</sub> Mode Nanosecond Lasers

[www.photonix.com](http://www.photonix.com)



Photonic Industries' DP Series diode-pumped solid-state (DPSS), Q-Switched, high energy, short pulse width lasers combine up to 50mJ pulse energy levels, TEM<sub>00</sub> output, and exceptional power efficiency with 10X lower heat load vs. closest competitors. With the ability to select and/or blend multiple wavelengths, the DP Series is an ideal, compact air-cooled package for industrial applications, from intra-marking glass, to repairing displays. Scientific applications also benefit where the high pulse energies align well for atomic excitation research or spectroscopy systems.

### Features

- **High pulse energy, TEM<sub>00</sub> output, with low pulse widths:**  
Up to 50 mJ at 6-10 ns pulse width range
- **Extremely efficient with 5X to 10X lower heat vs. the competition**  
5% to 10% conversion from wall power.
- **Reliable, low COO, non-consumable design**  
Patented intracavity harmonic UV & Green generation, with no indexing of the harmonic crystals
- **Small, air-cooled form factor**  
Rad-cooling™ option available
- **Multiwavelength Selectable (MWS) & Multiwavelength Blended (MWB) options**  
Select and/or blend IR, Green, UV, & DUV
- **Continuously variable pulse repetition rates**  
1 Hz to 100 Hz, or up to 1 kHz and higher
- **Superior beam pointing stability:**  
< 25 μrad
- **Total Pulse Control for ideal integration into systems:**  
Duty Control  
PEC (Power or Pulse Energy Control)

### Applications

- **Cutting, drilling, welding, scribing, marking, intra-marking, patterning,**
- **dielectric grooving, de-paneling, annealing, repair**
- **Ion Generation Systems, Atomic Excitation, Atomic/Quantum Physics Research**
- **Flat Panel Display Repair Systems, LCD/LED/OLED ZAP Repair**
- **Laser Induced Breakdown Spectroscopy (LIBS), Spectroscopy Systems**
- **Non-destructive Testing (NDT), Laser Ultrasonics, Acoustic Microscopy, Photoacoustics,**
- **Pulsed Laser Deposition (PLD)**
- **OPO pumping**

## Specifications – DP Series High Pulse Energy Nanosecond Lasers

	DP5	DP20	DP1k-20	DP50	
<b>Beam and output specifications</b>					
Wavelengths <sup>1</sup> available, single or multi-wavelength selectable and/or blended output	1064 nm, 532 nm, 355 nm, 266 nm			1030 nm, 515 nm, 343 nm, 257 nm	
Maximum pulse energy <sup>1,2</sup> , single-wavelength output	IR	5 mJ	20 mJ	20mJ	50 mJ
	GRN	3 mJ	12 mJ	12 mJ	30 mJ
	UV	2 mJ	8 mJ	8 mJ	20 mJ
Pulse repetition rate	Single shot to 100 Hz		Single shot to 1 kHz	Single shot to 100 Hz	
Pulse width range <sup>3</sup>	6-10 ns				
Multi-wavelength output types	[IR/GRN], [GRN/DUV], [IR/GRN/UV], or [IR/GRN/DUV]				
	Blended (-MWB)	All wavelengths come out of a single exit port blended.			
	Blended/Selectable (-MWB/S)	One, two, or three different wavelengths come out of a single exit port blended. The specific wavelength blend combination is user-selectable via the software GUI.			
	Selectable (-MWS)	Each individual wavelength is isolated and user-selectable via the software GUI.			
Pulse energy stability	< 3% rms, measured at ambient temperature of ± 2°C				
Long-term stability	3% rms, measured over 8 hours ± 1°C				
Beam spatial mode <sup>5</sup>	TEM <sub>00</sub> M <sup>2</sup> < 1.3				
Beam pointing stability	< 25 µrad				
Beam divergence	< 4 mrad				
Beam diameter <sup>6</sup>	~1 mm, at exit				

### Operational and system characteristics

Interface	RS232, Ethernet, Software GUI, External TTL Triggering			
Electrical requirement	100-240 V AC, Line Frequency 50-60 Hz			
	15 V DC, 7 A	24 V DC, 3 A	32 V DC, 11 A	
Power consumption	< 10 W	< 50W	< 200 W	< 100 W
Warm-up time	< 5 minutes from standby, < 10 minutes from cold start			
Ambient	15°C to 30°C (59°F to 86°F) Operating Range, RH 90% Max, non-condensing			
Cooling system <sup>7</sup>	Passively cooled, no air-cooling fan required	Air-cooling fan	Rad-cooling™ or option for air-cooling fans	Rad-cooling™
Dimensions <sup>8</sup> (LxWxH)	11 x 5 x 3.25 in	12.50 x 6.75 x 3.88 in	12.50 x 6.75 x 3.88 in (air-cooling H = 5.95 in)	12.50 x 6.75 x 3.88 in

[1] For DUV 257 nm or 266 nm output, please contact us. [2] Depending on pulse energy needed, air-cooling or rad-cooling™ systems can be used for laser head heat removal. [3] Precise pulse width range dependent on model and configuration chosen. [4] Pulse energy output efficiency for each wavelength dependent on multi-wavelength output option chosen. Pulse energy is constant across the entire pulse repetition rate range. [5] Typical M<sup>2</sup> values are lower depending on wavelength output type and model. [6] Specified value in the IR. [7] Rad-cooling™ is a special cooling system for highly effective heat removal while also isolating vibrational noise away from the laser head (low dB). Please contact us for more information. [8] The DP Series Lasers are all-in-one (AIO) and do not require a separate controller. All connections for operation and control of the laser are found on the back panel of the AIO laser. [NB] For further details on the multi-wavelength output options, please contact us.

### How to order

Format	DP	xx	-	xxx	[xx/xx/xx]
Designation criteria	DP	5, 20, 1k-20, or 50	-	MWB, MWB/S, or MWS	IR, GRN, UV, or DUV
Examples	DP20-MWB/S [GRN/DUV], DP1k-15 [IR], DP5 [GRN], etc.				

## Dimensional Drawings

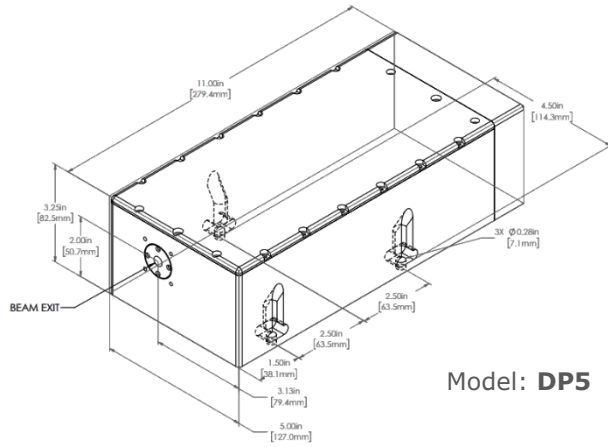

Model: **DP5**

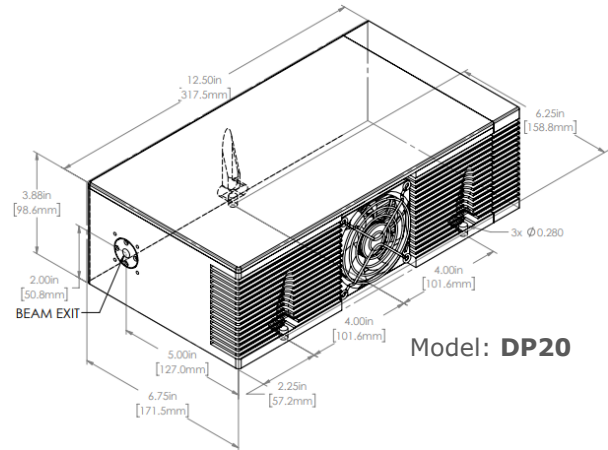

Model: **DP20**

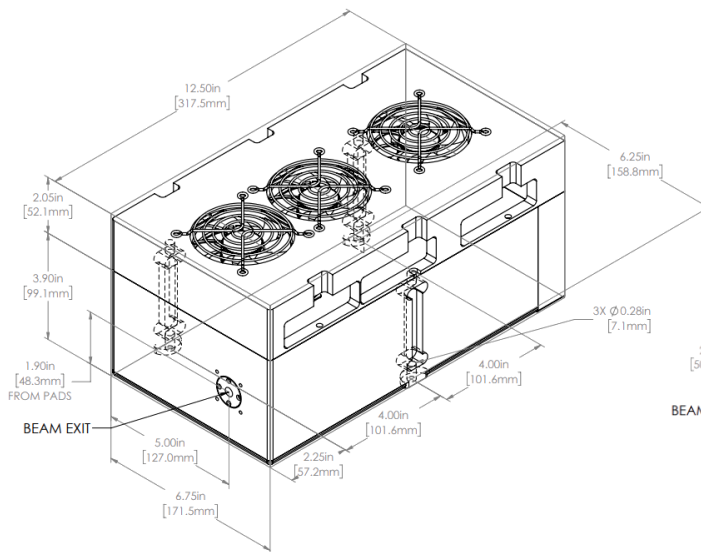

Model: **DP1k Air-Cooled**

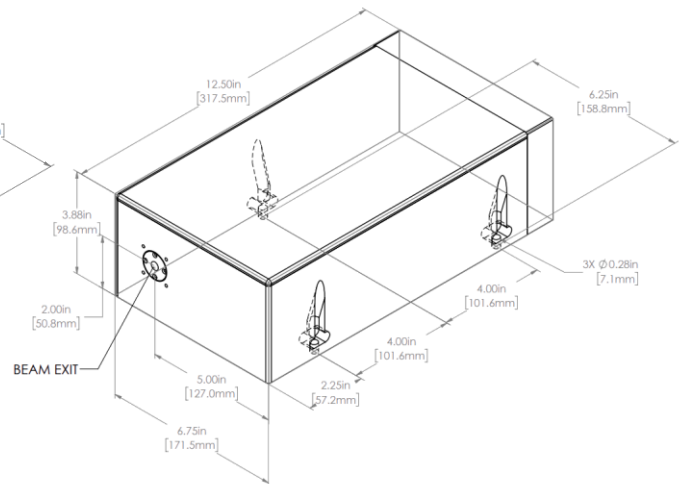

Model: **DP1k, DP50 Rad-Cooled™**

Product specifications, characteristics, and dimensional drawings are subject to change without notice.

Photonics Industries conforms to provisions of US 21 CFR 1040.10 & 1040.11 and is made under one or more US patents listed below: 9,531,147, 8,817,831, 7,869,471, 7,346,092, 7,082,149, 7,079,557, 6,999,483, 6,980,574, 6,961,355, 6,842,293, 6,762,405, 6,690,692, 6,587,487, 6,584,134, 6,366,596, 6,356,578, 6,327,281, 6,246,707, 6,229,829, 6,108,356, 6,061,370, 6,028,620, 5,936,983, 5,898,717 and Pending Patents

Copyright © 2024 by Photonics Industries International, Inc.

Main Headquarters: 1800 Ocean Ave, Ronkonkoma, New York 11779, United States

Photonics Industries International is the pioneer of intracavity harmonic lasers and is at the forefront of developing, manufacturing and marketing a wide range of nanosecond, sub-nanosecond, picosecond and femtosecond lasers for industrial, scientific, defense, and medical industries. Check out our products and see how we can help you apply our lasers to your needs.

[Website](#) - [Products](#) - [Applications](#) - [Company](#) - [Contact](#) - [International Network](#)

