

FS Series Femtosecond Lasers

www.photonix.com

Photonics Industries FS Series Femtosecond Lasers offer short pulse widths (< 450 fs), high output power in a market-leading compact form factor (up to 100 W at wavelength 1030 nm), and high pulse repetition rates up to 8 MHz or greater (fixed at ~32 MHz available on request). With high single pulse energy, up to 700 μ J, all-in-one (AIO) form factor (no separate chassis for PSU or utility), and high-power efficiencies (low power consumption less than 600 W), the FS is an ideal laser for industrial system integration or for scientific research applications.

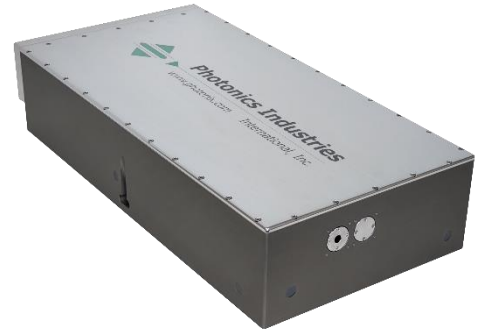

Applications

- Ultrafast high precision cutting, drilling, welding, scribing, marking, intra-marking, patterning, de-paneling, repair
- Flat Panel Display Repair, LCD/LED/OLED Repair
- Hydrophobic Material Manufacturing, Hydrophilic Material Manufacturing, Ultrafast Laser Assisted Etching (ULAE) Systems, Complex 3D Surface Micro-structuring
- Terahertz (THz) Generation, High Harmonic Generation (HHG), X-Ray Generation, OPO Amplifier Systems
- Laser Particle Accelerator Systems
- Angle/Time-resolved Photoemission Spectroscopy Systems, Femtosecond-stimulated Raman Spectroscopy (FSRS) Systems, Multi-photon Fluorescence Microscopy Systems

Features

- High power laser (up to 100 W in IR) with ultra-short pulse (< 450 fs)
- Specifiable pulse width
- Wide range of wavelengths: 1030 nm, 515 nm, 343 nm, and 257 nm available upon request.
- The most compact, rugged, all-in-one fs laser
- Pulse repetition rates up to ~32MHz
- Excellent TEM00 beam with typical $M^2 < 1.3$
- Exceptional Beam Pointing Stability < 25 μ rad
- PEC (Power or Pulse Energy Control)
- PSO (Position Synchronized Output) support for external triggering to any arbitrary PRF while maintaining a constant, stable pulse energy with low jitter.
- Burst Mode for individually controllable bursts of pulses with variable separations.
- POD (Pulse-On-Demand), where a burst of pulses with separation equal to the PRF, can be triggered internally, externally, or continuously, while maintaining constant pulse energy.
- Air-cooled option available

Specifications – FS Series Femtosecond Lasers, IR Models

	FS1-1030-5	FS1-1030-50	FS2-1030-100
Beam and output specifications			
Wavelength ¹	1030 ± 5 nm		
Average power	5 W at 1 MHz	50 W at 1 MHz	100 W at 1 MHz
Pulse energy	8 µJ at 100 kHz	250 µJ at 100 kHz	700 µJ at 100 kHz
Pulse width ²	< 450 fs to 5 ps		
Pulse repetition rate ^{3, 4}	Single shot to 2 MHz (option up to 8 MHz)		
Pulse-to-pulse stability ⁵	~1% rms		
Long term power stability ⁶	≤ 1% rms		
Beam spatial mode	TEM ₀₀ M ² < 1.3		
Beam pointing stability	< 25 µrad		

Operational specifications and system characteristics

Interface	RS232, Ethernet, Software GUI, External TTL Triggering		
Warm-up time	< 30 minutes		
Electrical requirement	100-240 V AC, Line Frequency 50-60 Hz		
	32 V DC, 28 A	32 V DC, 36 A	
Power consumption ⁷	< 600 W	< 900 W	
Climate	Ambient 15°C to 30°C (59°F to 86°F) Operating Range, Relative Humidity 90% Maximum, non-condensing		
Dimensions (LxWxH)	20 x 10 x 4.25 in.	22 x 10 x 4.25 in.	
Vibrational tolerance	Up to 3g		
Cooling system ⁸	Water-cooled		

[1.] Multi-wavelength options are available. Contact us. [2.] Specifiable pulse width. [3.] Lower repetition rates, down to single shot, achieved by utilizing PSO or POD features. [4.] Fixed pulse repetition rate at ~32 MHz available on request. [5.] Measured at ambient temperature ± 2°C. [6.] Measured over 8 hours ± 1°C. [7.] Power consumption data does not include an external chiller's power consumption. [8.] Air-cooled option available for low power FS Series models. Please contact us for more information. [NB] All specifications are at the optimized repetition rate.

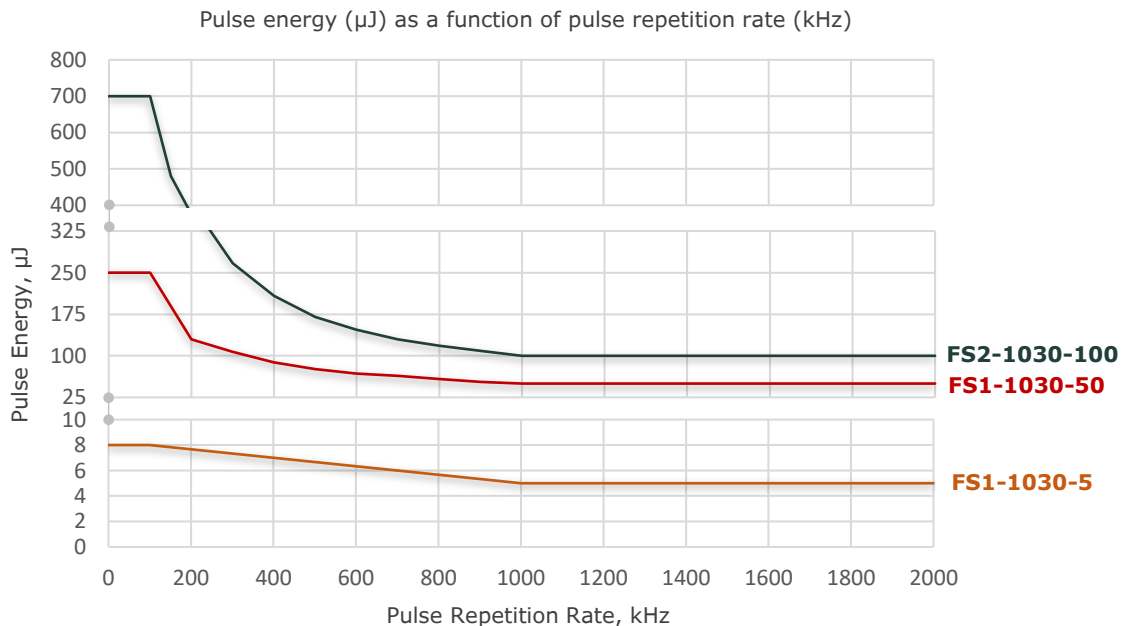

Specifications – FS Series Femtosecond Lasers, GRN Models

	FS1-515-2.5	FS1-515-25	FS2-515-50
Beam and output specifications			
Wavelength ¹	515 ± 3 nm		
Average power	2.5 W at 1 MHz	25 W at 1 MHz	50 W at 1 MHz
Pulse width ²	< 400 fs to 5 ps		
Pulse repetition rate ^{3, 4}	Single shot to 2 MHz (option up to 8 MHz)		
Pulse-to-pulse stability ⁵	< 2% rms		
Long term power stability ⁶	≤ 1% rms		
Beam spatial mode	TEM ₀₀ M ² ≤ 1.3		
Beam pointing stability	≤ 25 μrad		

Operational specifications and system characteristics

Interface	RS232, Ethernet, Software GUI, External TTL Triggering		
Warm-up time	< 30 minutes		
Electrical requirement	100-240 V AC, Line Frequency 50-60 Hz		
	32 V DC, 28 A	32 V DC, 36 A	
Power consumption ⁷	< 600 W	< 900 W	
Climate	Ambient 15°C to 30°C (59°F to 86°F) Operating Range, Relative Humidity 90% Maximum, non-condensing		
Dimensions (LxWxH)	20 x 10 x 4.25 in.	22 x 10 x 4.25 in.	
Vibrational tolerance	Up to 3g		
Cooling system ⁸	Water-cooled		

[1.] Multi-wavelength options are available. Contact us. [2.] Specifiable pulse width. [3.] Lower repetition rates, down to single shot, achieved by utilizing PSO or POD features. [4.] Fixed pulse repetition rate at ~32 MHz available on request. [5.] Measured at ambient temperature ± 2°C. [6.] Measured over 8 hours ± 1°C. [7.] Power consumption data does not include an external chiller's power consumption. [8.] Air-cooled option available for low power FS Series models. Please contact us for more information. [NB] All specifications are at the optimized repetition rate.

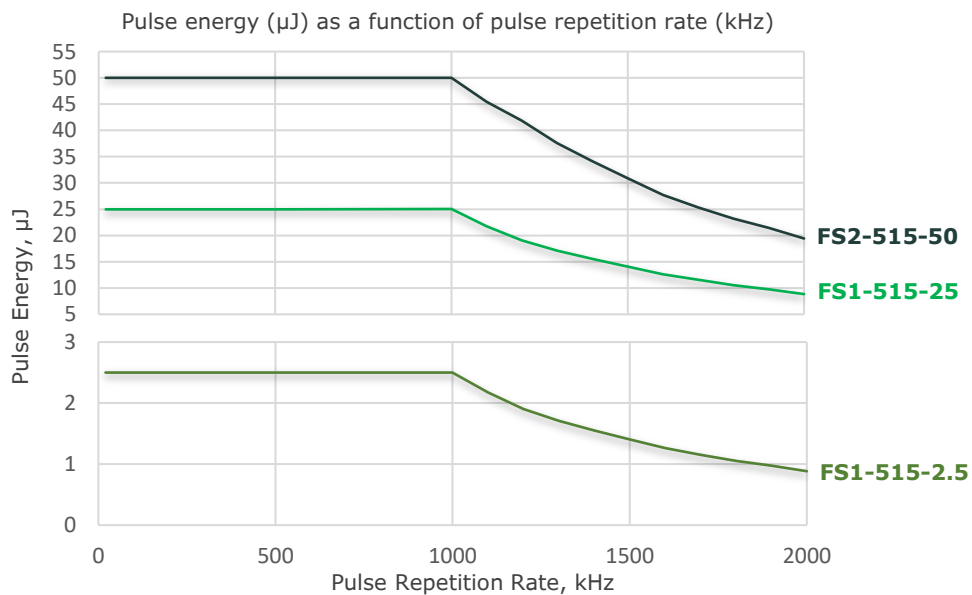

Specifications – FS Series Femtosecond Lasers, UV Models

	FS1-343-1	FS1-343-15	FS2-343-30
Beam and output specifications			
Wavelength ¹	343 ± 2 nm		
Average power	1 W at 1 MHz	15 W at 1 MHz	30 W at 1 MHz
Pulse width ²	< 400 fs to 5 ps		
Pulse repetition rate ^{3, 4}	Single shot to 2 MHz (option up to 8 MHz)		
Pulse-to-pulse stability ⁵	~2% rms		
Long term power stability ⁶	≤ 1% rms		
Beam spatial mode	TEM ₀₀ M ² ≤ 1.3		
Beam pointing stability	≤ 25 μrad		

Operational specifications and system characteristics

Interface	RS232, Ethernet, Software GUI, External TTL Triggering		
Warm-up time	< 30 minutes		
Electrical requirement	100-240 V AC, Line Frequency 50-60 Hz		
	32 V DC, 28 A	32 V DC, 36 A	
Power consumption ⁷	< 600 W	< 900 W	
Climate	Ambient 15°C to 30°C (59°F to 86°F) Operating Range, Relative Humidity 90% Maximum, non-condensing		
Dimensions (LxWxH)	20 x 10 x 4.25 in.	29.5 x 10 x 4.25 in.	
Vibrational tolerance	Up to 3g		
Cooling system ⁸	Water-cooled		

[1.] Multi-wavelength options are available. Contact us. [2.] Specifiable pulse width. [3.] Lower repetition rates, down to single shot, achieved by utilizing PSO or POD features. [4.] Fixed pulse repetition rate at ~32 MHz available on request. [5.] Measured at ambient temperature ± 2°C. [6.] Measured over 8 hours ± 1°C. [7.] Power consumption data does not include an external chiller's power consumption. [8.] Air-cooled option available for low power FS Series models. Please contact us for more information. [NB] All specifications are at the optimized repetition rate.

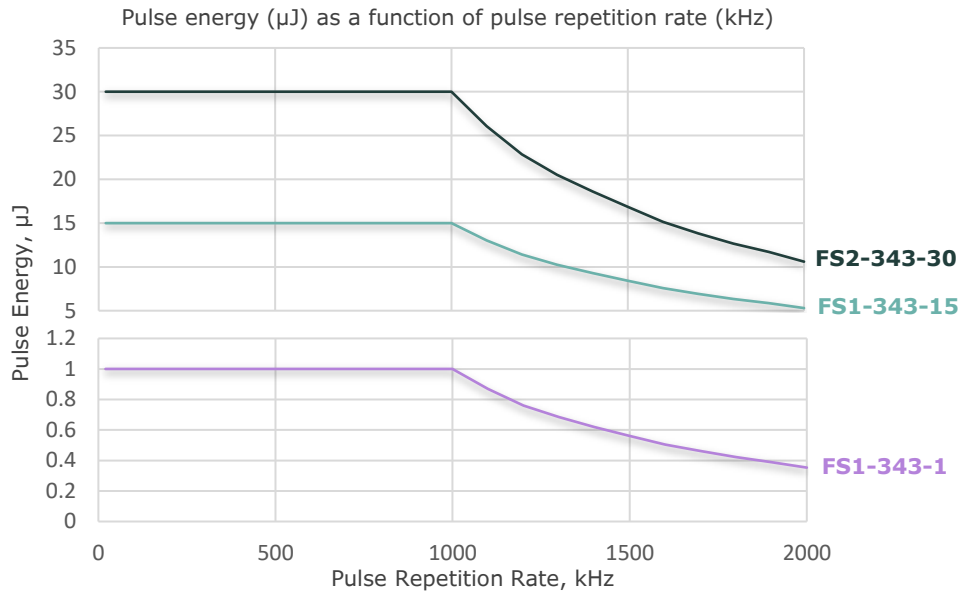

Features

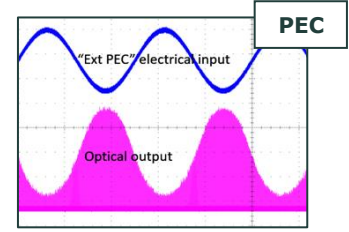
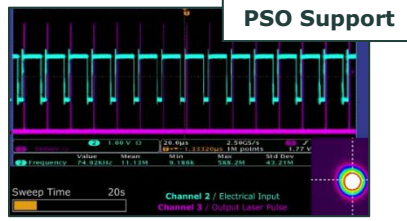
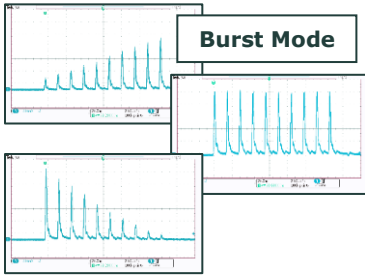

Dimensional Drawings

FS1 1030 nm, 515 nm, and 343 nm

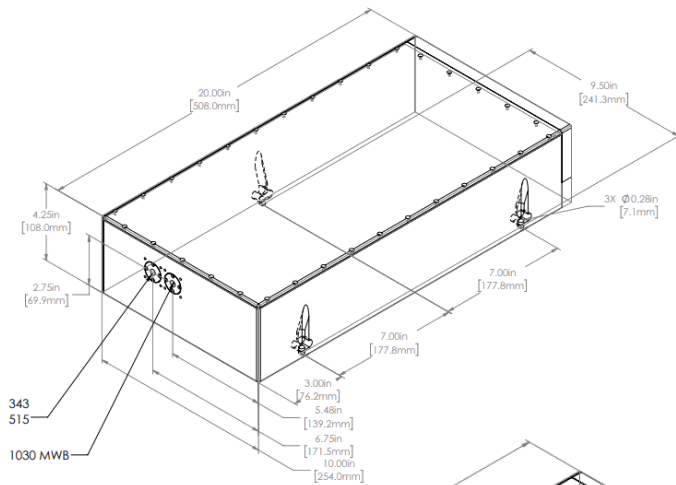

FS2 1030 nm, and 515 nm

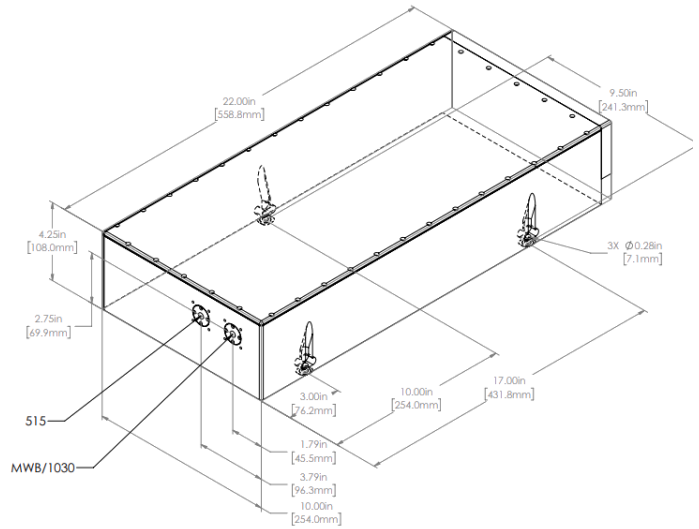

FS2 343 nm

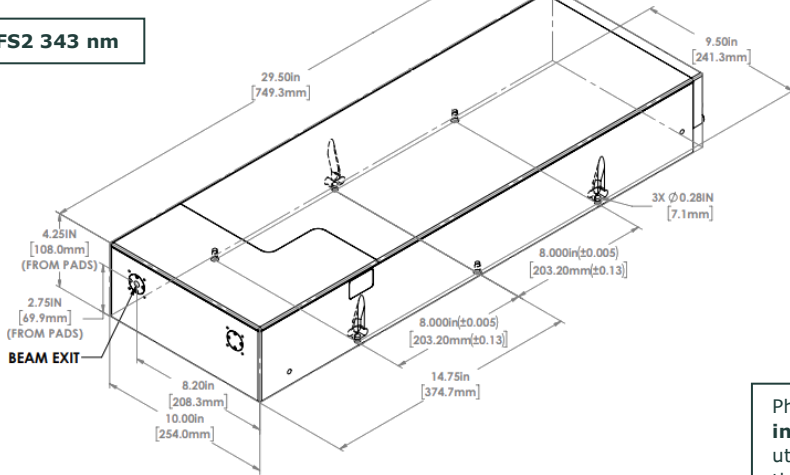

Photonics Industries FS Series femtosecond lasers are **all-in-one (AIO)** and do not require a separate controller or utility module. All connections for operation and control of the laser can be found on the back panel of the AIO laser.

Due to Photonics Industries' commitment to continuous product improvement, specifications and drawings are subject to change without notice.

Photonics Industries conforms to provisions of US 21 CFR 1040.10 & 1040.11 and is made under one or more US patents listed below: 9,531,147, 8,817,831, 7,869,471, 7,346,092, 7,082,149, 7,079,557, 6,999,483, 6,980,574, 6,961,355, 6,842,293, 6,762,405, 6,690,692, 6,587,487, 6,584,134, 6,366,596, 6,356,578, 6,327,281, 6,246,707, 6,229,829, 6,108,356, 6,061,370, 6,028,620, 5,936,983, 5,898,717 and Pending Patents

Copyright © 2024 by Photonics Industries International, Inc.

Main Headquarters: 1800 Ocean Ave, Ronkonkoma, New York 11779, United States

Photonics Industries International is the pioneer of intracavity harmonic lasers and is at the forefront of developing, manufacturing and marketing a wide range of nanosecond, sub-nanosecond, picosecond and femtosecond lasers for industrial, scientific, defense, and medical industries. Check out our products and see how we can help you apply our lasers to your needs.

